

ANX POE External Back-up (PoE has priority)



This application note shows how an external power supply can be used as a back-up, in case the Power Sourcing Equipment (PSE) fails (see Figure 1).

When U1 is operating normally, the power to the device is sourced from the +VDC output via D1.

R1 is used to increase the output to allow for the forward voltage drop of D1. The voltage on the base of Q1 will be held high enough by D2 to ensure that the transistor is off. It is very important that the voltage at the External Power Input is not higher than the output of U1. If this happens the External Power Input will provide power to the load and may result in U1 being damaged (with no minimum load connected).

If the PSE fails, U1 will shut down. When the +VDC output voltage drops, Q1 will switch on and the power to the device will be supplied from the External Power Input.

When the PSE power is restored +VDC will return, switching Q1 off and supplying the power to the device via D1.

Q1 is a SOT23 package and must be connected to sufficient tracking surface area to provide a heat-sink for the device.

C1 must be connected across the output of U1, as it is used by the module.

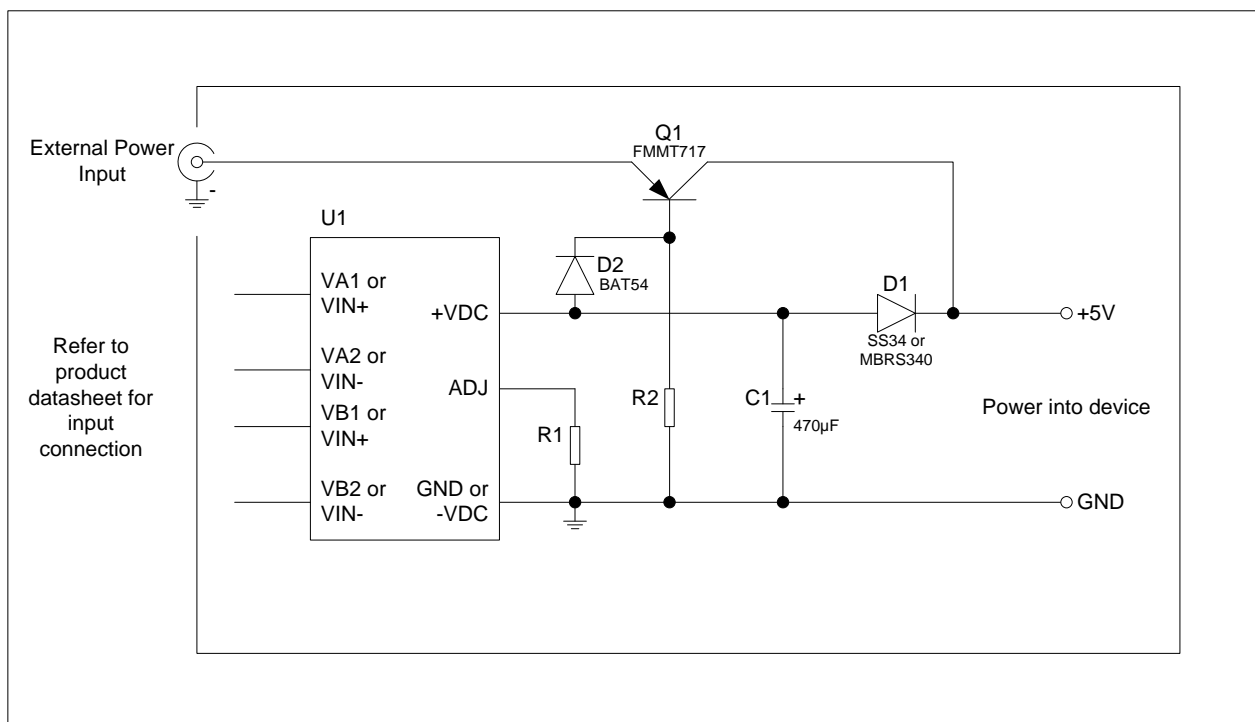

Figure 1: External Back-up Supply Circuit

ANX POE External Back-up

(PoE has priority)



Table 1 shows the range of modules that can be used for U1, the external input voltage and the value of the external components.

U1 Module	External Power Input	R1	R2
Ag9033	3.3V	18K Ω (125mW)	47 Ω (250mW)
Ag9050	5.0V	0 Ω	82 Ω (500mW)
Ag9120	12.0V	150K Ω (125mW)	1K1 Ω (250mW)
Ag9203	3.3V	0 Ω	47 Ω (250mW)
Ag9205	5.0V	39K Ω (125mW)	82 Ω (500mW)
Ag9403	3.3V	0 Ω	47 Ω (250mW)
Ag9405	5.0V	39K Ω (125mW)	82 Ω (500mW)
Ag9412	12.0V	39K Ω (125mW)	1K1 Ω (250mW)
Ag9424	24.0V	150K Ω (125mW)	2K4 Ω (250mW)
Ag9603	3.3V	0 Ω	47 Ω (250mW)
Ag9605	5.0V	22K Ω (125mW)	82 Ω (500mW)
Ag9612	12.0V	39K Ω (125mW)	1K1 Ω (250mW)
Ag9705	5.0V	39K Ω (125mW)	82 Ω (500mW)
Ag9712	12.0V	39K Ω (125mW)	1K1 Ω (250mW)

Table 2: Component Values